

COLT











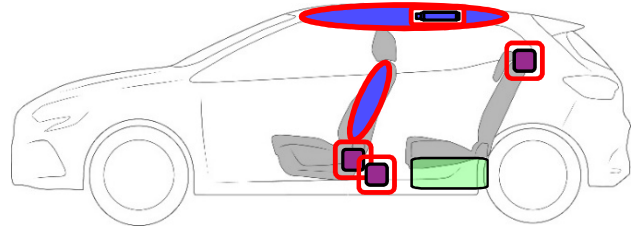
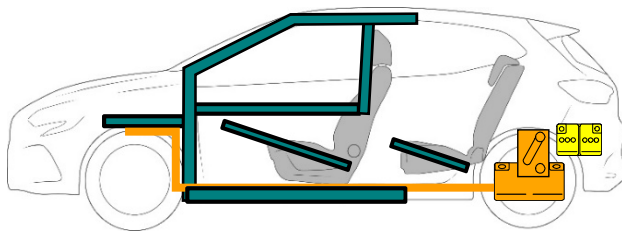
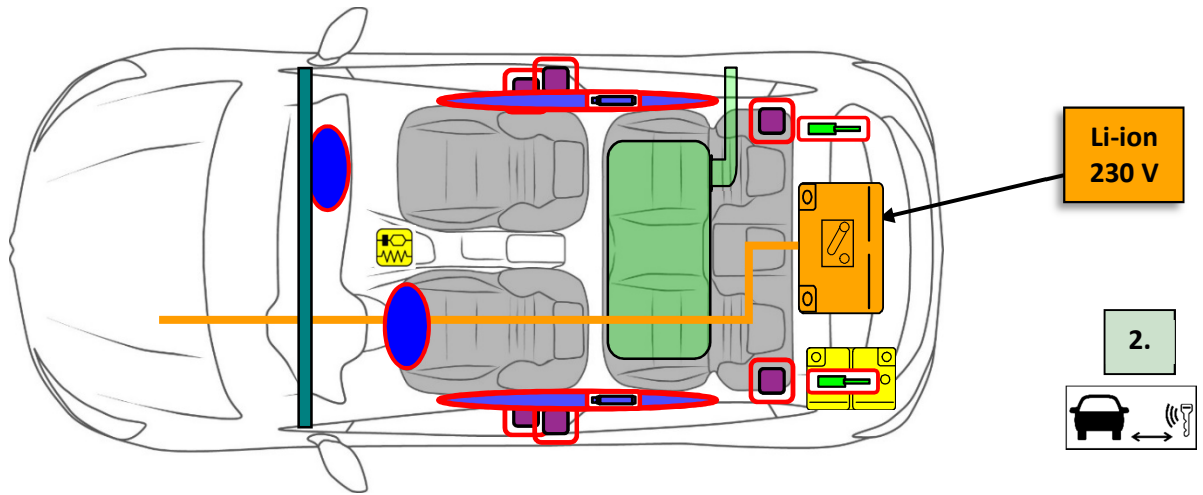











VEILIGHEIDSHANDLEIDING MITSUBISHI COLT HEV

INFORMATIE VOOR EERSTE- EN TWEEDELIJNSHULPDIENSTEN

MODELJAAR 2024





	Airbag		Stored gas inflator		Seat belt pretensioner		SRS control unit		Pedestrian protection active system
	Automatic rollover protection system		Gas strut / Preloaded spring		High strength zone		Zone requiring special attention		
	Battery low voltage		Ultra-capacitor, low-voltage		Fuel tank		Gas tank		Safety valve
	Battery pack, high-voltage		High voltage power cable		High voltage component		Fuse box disabling high voltage		High voltage ultra-capacitor

	ID No. VBEH-ENRS-EN01	Version No. 01	Version Date. 07/2023	Page 1/4
--	--------------------------	-------------------	--------------------------	-------------

1. Identification / recognition

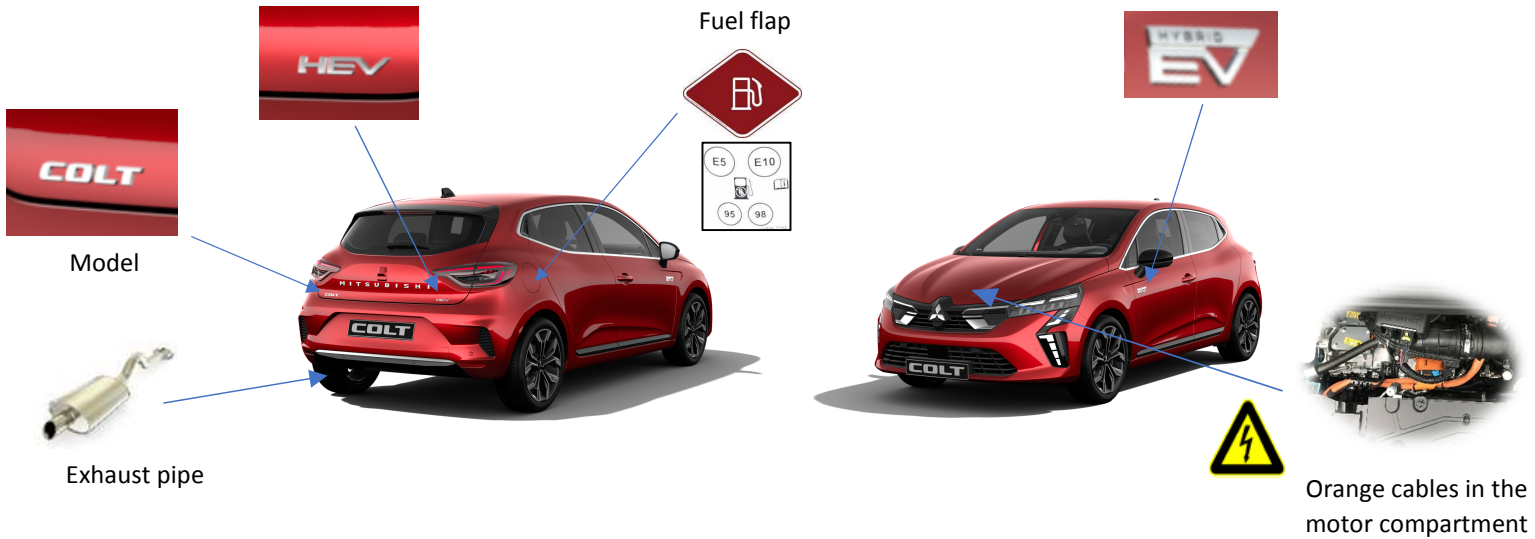

2. Immobilisation / stabilisation / lifting

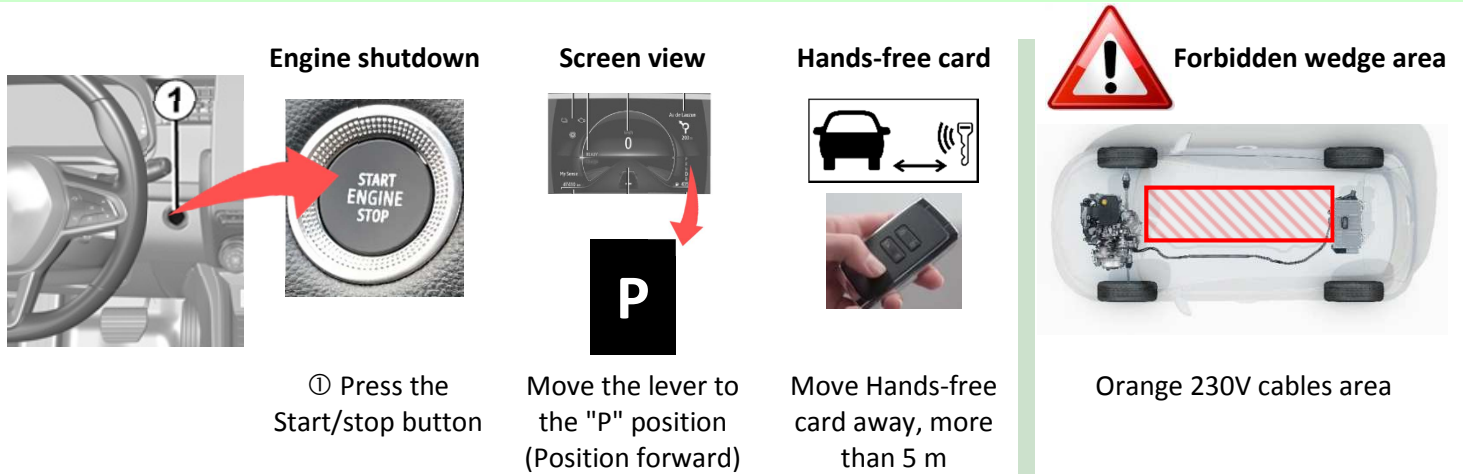

3. Disable direct hazards / safety regulations

12 Volts Battery

In the trunk

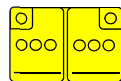
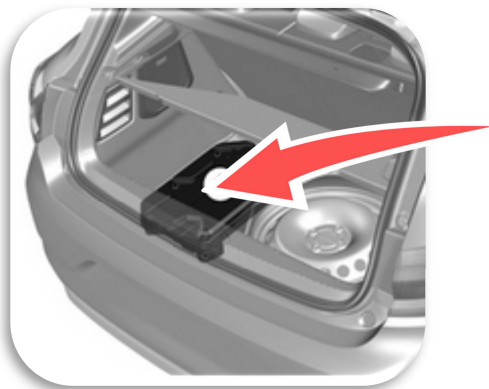

- 1- Switch off the ignition
- 2- Disconnect the negative terminal (-)

	ID No.	Version No.	Version Date.	Page
	VBEH-ENRS-EN01	01	07/2023	2/4

3. Disable direct hazards / safety regulations (next)

230 Volts battery

Only if cutting operation is necessary :

Disconnection of the 230 Volts battery by removing the service plug.

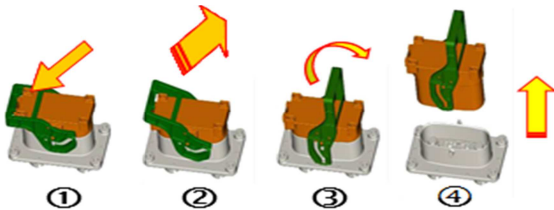
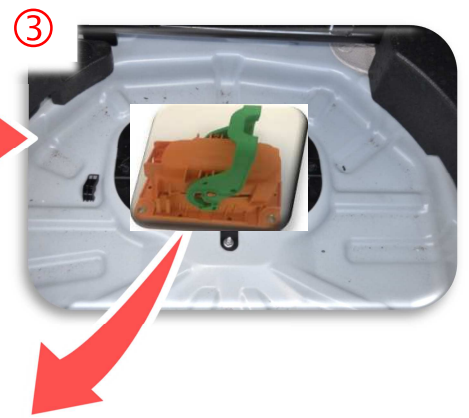
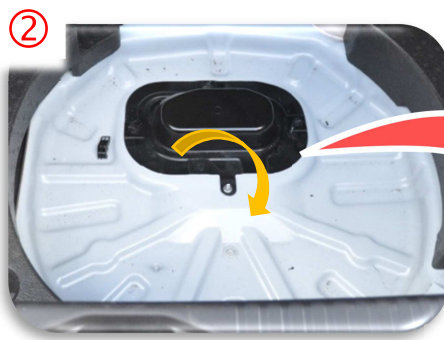
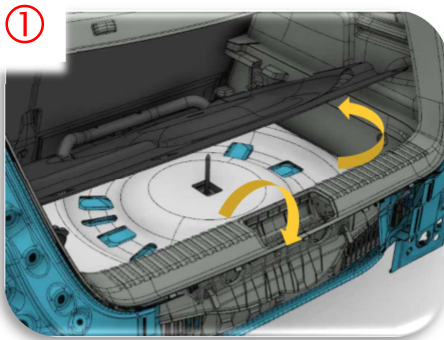
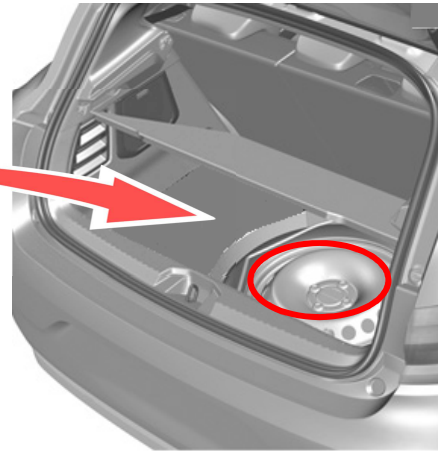
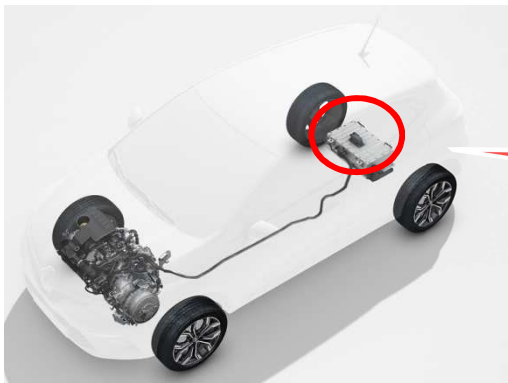

① & ② Press the orange release tab while lifting the green lever

③ & ④ Pull the lever to remove the service plug

4. Access to the occupants

STEERING COLOMN



Steering column hollow and breakable with tools

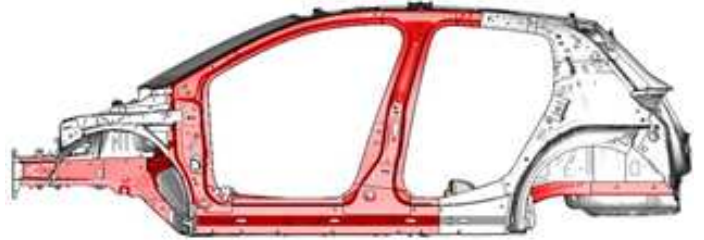
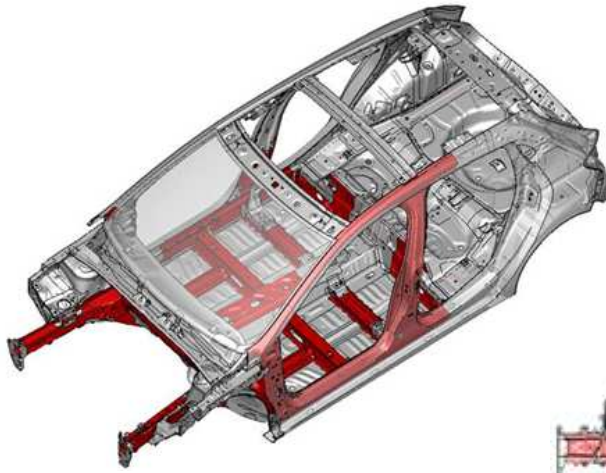

	ID No.	Version No.	Version Date.	Page
	VBEH-ENRS-EN01	01	07/2023	3/4

HARDENED STEEL HIGH ELASTIC LIMIT (HEL)



5. Stored energy / liquids / gases / solids

	Lithium-ion	1.2 kW.h	230 V
---	-------------	----------	-------

	 	39 L
--	---	------

6. In case of fire

TAILGATE GAS STRUTS



Risk of missile effect of tailgate gas struts

10. Explanation of pictograms used



Hybrid Electric Vehicle on fuel of liquid group 2

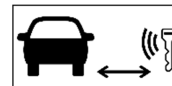

Remove smart key

	ID No.	Version No.	Version Date.	Page
	VBEH-ENRS-EN01	01	07/2023	4/4